

# Rod Ends Series K - Stainless, Maintenance Free

## Series GARSW

Rod Ends with male thread made from stainless steel with PTFE liner, maintenance free

For use at high dynamic pressure and tension loads in corrosive environments

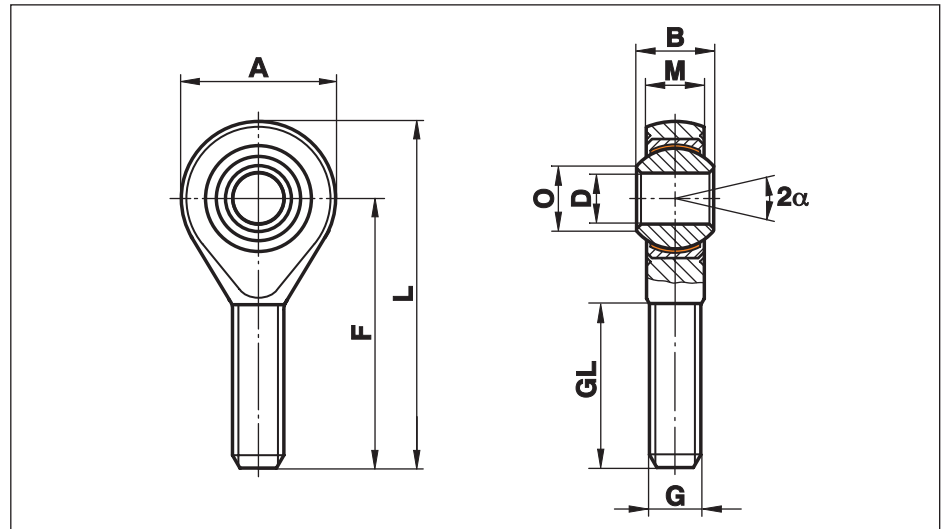

Size (D)	B	M	A	F	L	O	G	GL	Static load C <sub>0</sub> kN	Dynamic load C kN	Limiting speed rev/min	Weight g
4 <sup>1)</sup>	7	5,25	14	30	37	6,5	M 4	19	2,5	5,1	—	9
5	8	6,00	18	33	42	7,7	M 5	20	6,2	7,5	600	13
6	9	6,75	20	36	46	8,9	M 6	22	8,8	9,3	530	20
8	12	9,00	24	42	54	10,4	M 8	25	16,1	16,7	420	33
10	14	10,50	28	48	62	12,9	M 10	29	25,5	23,4	350	56
12	16	12,00	32	54	70	15,4	M 12	33	34,5	32,0	300	87
14	19	13,50	36	60	78	16,8	M 14	38	39,5	42,0	260	129
16	21	15,00	42	66	87	19,3	M 16	40	60,5	52,5	230	189
18	23	16,50	46	72	95	21,8	M 18x1,5	44	73,0	64,0	210	267
20	25	18,00	50	78	103	24,3	M 20x1,5	47	83,0	78,0	190	348
22	28	20,00	54	84	111	25,8	M 22x1,5	51	100,0	97,0	170	443
25	31	22,00	60	94	124	29,6	M 24x2	57	118,0	122,0	150	600
30	37	25,00	70	110	145	34,8	M 30x2	71	155,0	168,0	130	1030
35	43	28,00	80	125	165	37,7	M 36x2	73	191,0	206,0	110	1600
40	49	35,00	90	142	187	44,2	M 42x2	78	235,0	286,0	100	2570

only for short-term revolutions recommended

## Materials:

**Housing:** Stainless steel to 1.4057, Aisi 431, forged, polished  
size 40 turned from stainless steel to 1.4057, Aisi 431

**Insert:** Special high strength bronze to CuSn8 with PTFE liner bonded to the inner surface

**Ball:** Bearing steel to 100Cr6, Aisi 52100, hardened, ground, polished, hard chrome plated on the running surface

**On request:** Insert: Stainless steel to 1.4571, Aisi 316Ti  
Ball: Stainless steel to 1.4034, Aisi 420C hardened, ground, polished  
or in stainless steel to 1.4401, Aisi 316 ground, polished

This series is also available sealed (see page 38) or with threaded bolt (see page 39).

<sup>1)</sup> Size 4 on request. Housing turned from stainless steel to 1.4305, Aisi 303